



BEARING ADAPTERS

Direct Drive Bearing Housings
Typical Applications: Brush Cutting

(913) 782-1238 (Tel)
(913) 782-4206 (Fax)
Sales@Eskridgeinc.com
www.Eskridgeinc.com
FORM: PSMD-B

SHEET 1 OF 10

MODEL 28

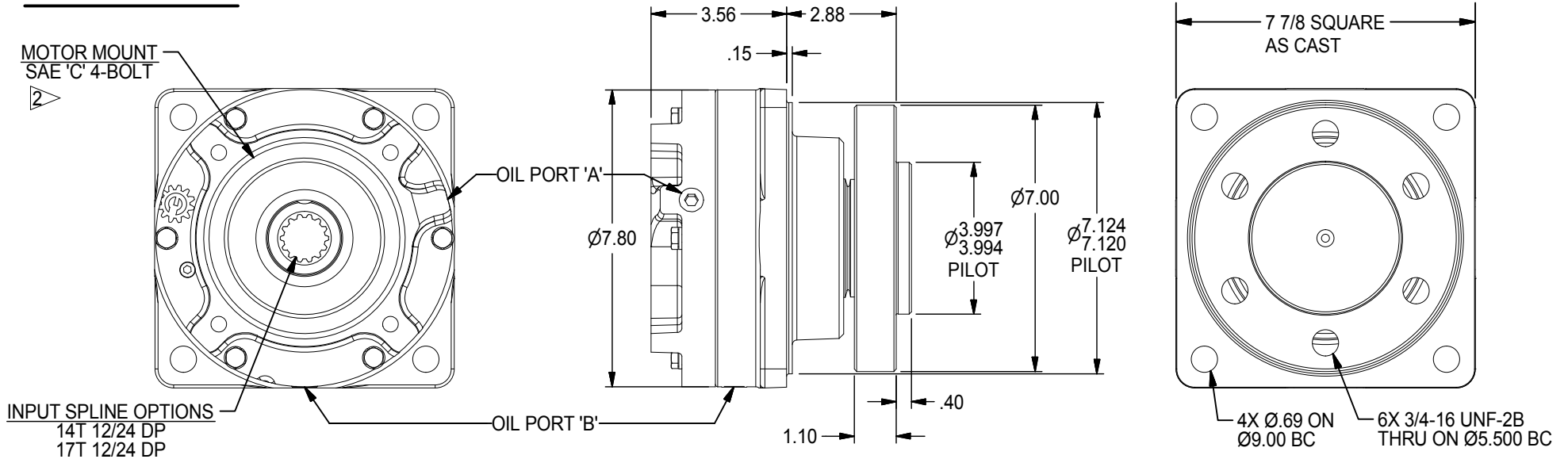

NOTES:

1. EQUIPPED WITH PATENTED LOAD-N-LOCK[®] SHAFT RETENTION SYSTEM.
2. SPECIFICATIONS DEFINED IN MOTOR MOUNT DIMENSIONS SECTION
3. VALUES ARE SHOWN IN INCHES.
4. OUTPUT ROTATION SAME DIRECTION AND SPEED AS INPUT ROTATION.

Oil Capacities

Mounting Position	
Horizontal	14 oz/.41 L Fill to Oil Port 'A'
Vertical Spindle Down	17 oz / .50 L Fill to Oil Port 'A'

ALL UNITS SHIPPED WITHOUT OIL
Use EP or API GL-5 Designated Lubricants
Approximate Unit Weight: 52 lb.

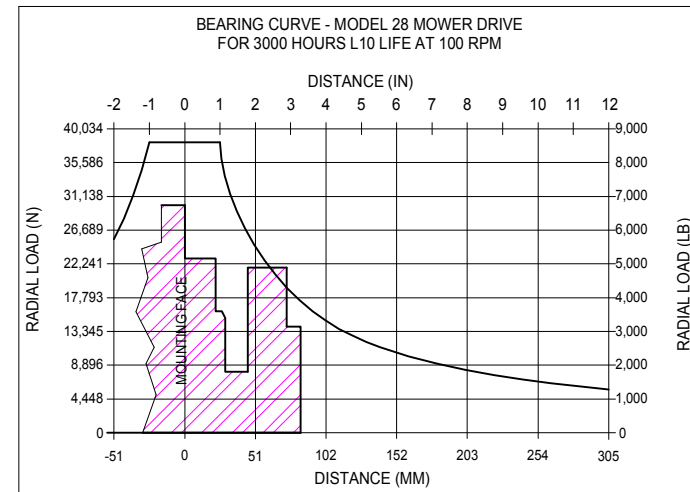

To adjust for loads and speeds other than those shown on above curve, use this formula:

$$\text{Adjusted Life (hours)} = 3000 \left(\frac{100 \text{ rpm}}{\text{Speed (Adjusted)}} \right) \times \left(\frac{\text{Load (Curve)}}{\text{Load (Adjusted)}} \right)^{10/3}$$



BEARING ADAPTERS

Direct Drive Bearing Housings
Typical Applications: Brush Cutting

(913) 782-1238 (Tel)
(913) 782-4206 (Fax)
Sales@Eskridgeinc.com
www.Eskridgeinc.com
FORM: PSMD-B
SHEET 2 OF 10

MODEL 28

Ordering Information

Example Part Number: 28LM1S4C4-1

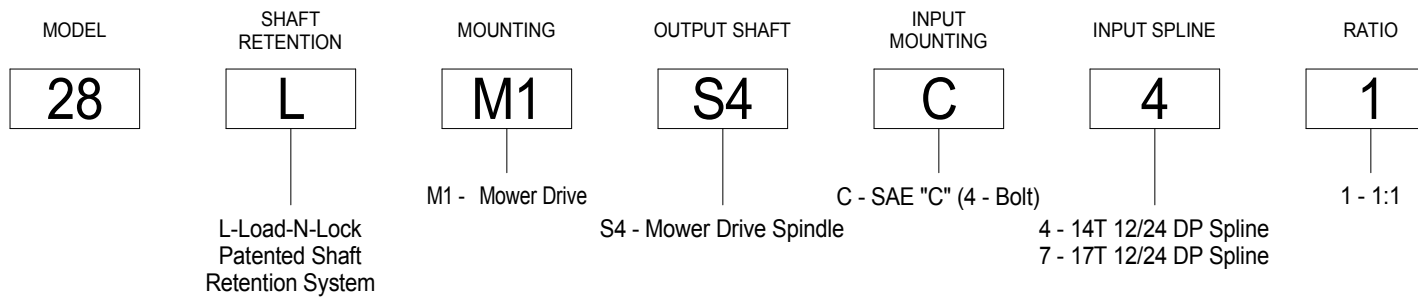



BEARING ADAPTERS

Direct Drive Bearing Housings
Typical Applications: Brush Cutting

(913) 782-1238 (Tel)
(913) 782-4206 (Fax)
Sales@Eskridgeinc.com
www.Eskridgeinc.com
FORM: PSMD-B
SHEET 3 OF 10

MODEL 50

MOTOR MOUNT OPTIONS

- SAE 'A' 4-BOLT
- SAE 'B' 2-BOLT
- SAE 'C' 4-BOLT

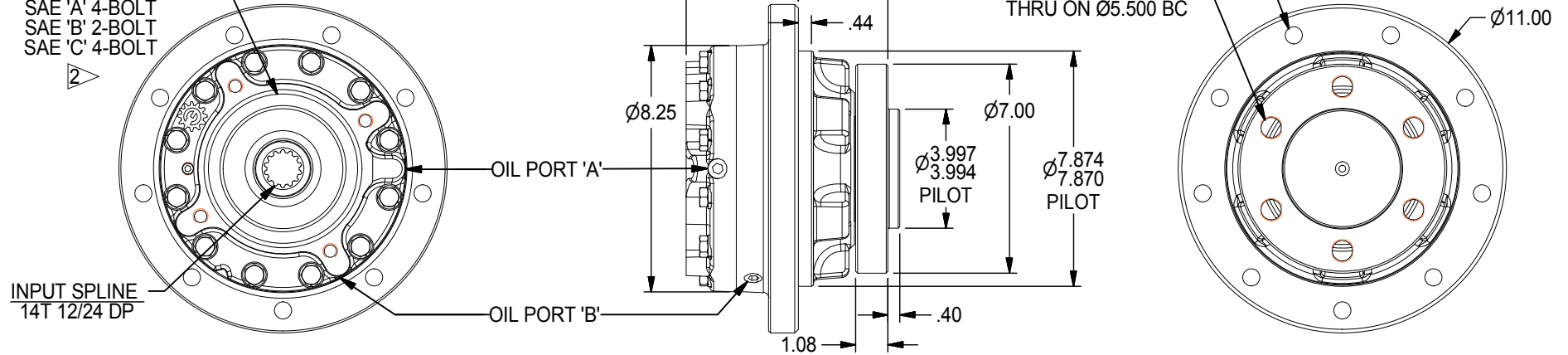

NOTES:

1. EQUIPPED WITH PATENTED LOAD-N-LOCK[®] SHAFT RETENTION SYSTEM.
2. SPECIFICATIONS DEFINED IN MOTOR MOUNT DIMENSIONS SECTION
3. VALUES ARE SHOWN IN INCHES.
4. OUTPUT ROTATION SAME DIRECTION AND SPEED AS INPUT ROTATION.

Oil Capacities

Mounting Position	
Horizontal	16 oz/.47 L Fill to Oil Port 'A'
Vertical Spindle Down	12 oz / .35 L Fill to Oil Port 'B'

Motor Mount DIM 'A'

SAE 'A'	3.42
SAE 'B'	3.42
SAE 'C'	3.77

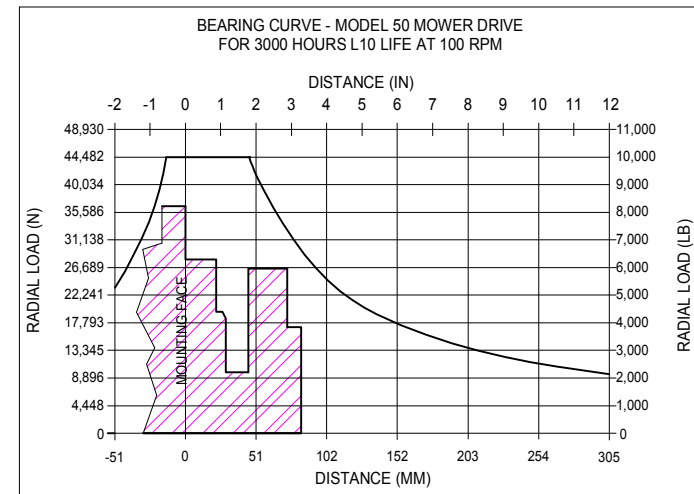

To adjust for loads and speeds other than those shown on above curve, use this formula:

$$\text{Adjusted Life (hours)} = 3000 \left(\frac{100 \text{ rpm}}{\text{Speed (Adjusted)}} \right) \times \left(\frac{\text{Load (Curve)}}{\text{Load (Adjusted)}} \right)^{10/3}$$

ALL UNITS SHIPPED WITHOUT OIL
Use EP or API GL-5 Designated Lubricants
Approximate Unit Weight: 71 lb.



BEARING ADAPTERS

Direct Drive Bearing Housings
Typical Applications: Brush Cutting

(913) 782-1238 (Tel)
(913) 782-4206 (Fax)
Sales@Eskridgeinc.com
www.Eskridgeinc.com
FORM: PSMD-B
SHEET 4 OF 10

MODEL 50

Ordering Information

Example Part Number: 50LM1S4C4-1

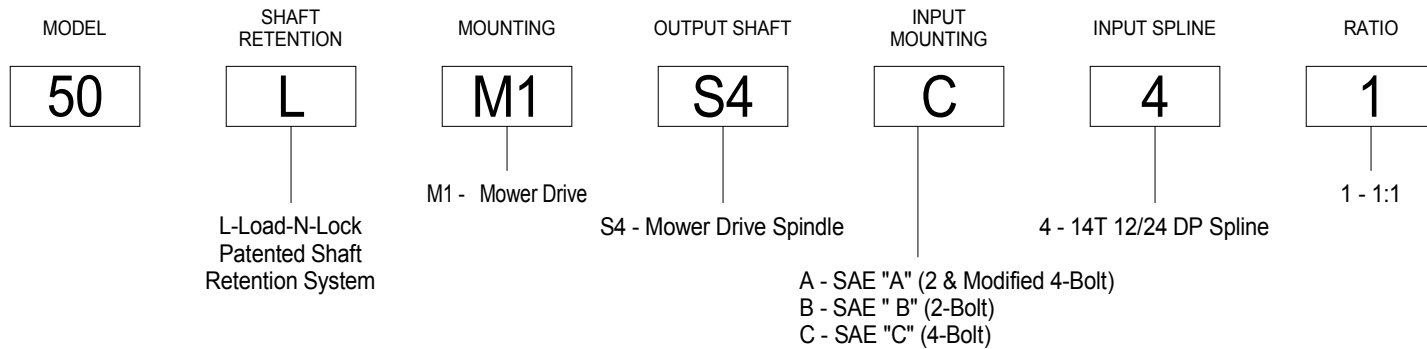



BEARING ADAPTERS

Direct Drive Bearing Housings
 Typical Applications: Brush Cutting

(913) 782-1238 (Tel)
 (913) 782-4206 (Fax)
 Sales@Eskridgeinc.com
 www.Eskridgeinc.com
 FORM: PSMD-B
 SHEET 5 OF 10

MODEL 70

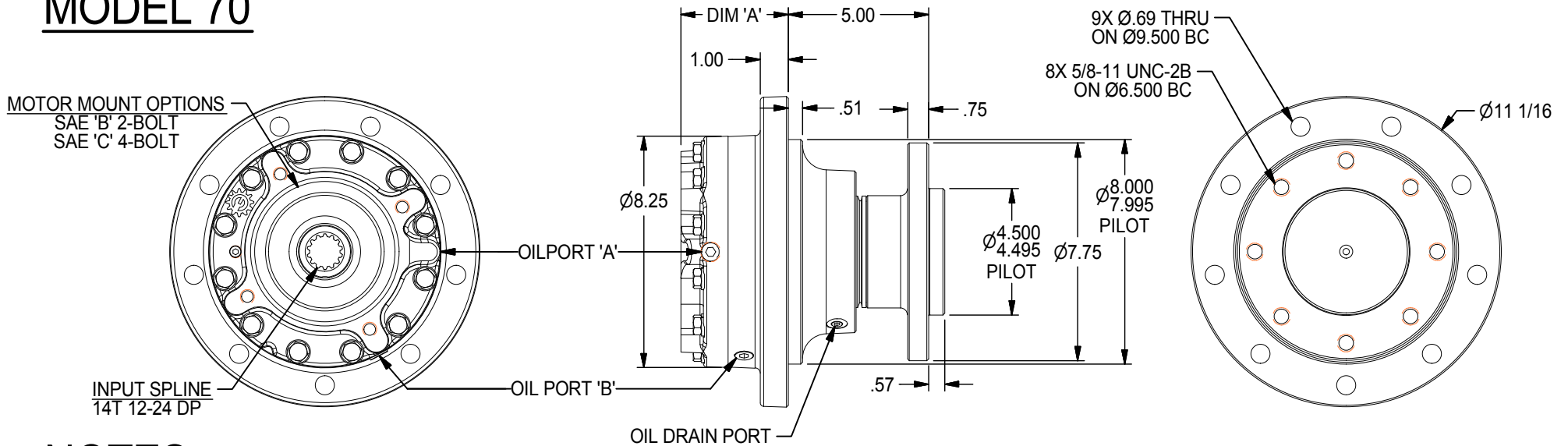

NOTES:

1. EQUIPPED WITH PATENTED LOAD-N-LOCK[®] SHAFT RETENTION SYSTEM.
2. SPECIFICATIONS DEFINED IN MOTOR MOUNT DIMENSIONS SECTION
3. VALUES ARE SHOWN IN INCHES.
4. OUTPUT ROTATION SAME DIRECTION AND SPEED AS INPUT ROTATION.

Oil Capacities

Mounting Position	Oil Capacity
Vertical Spindle Down	14 oz/.41 L Fill to Oil Port 'B'

Motor Mount DIM 'A'

Motor Mount	DIM 'A'
SAE 'B'	3.48
SAE 'C'	3.83

ALL UNITS SHIPPED WITHOUT OIL
 Use EP or API GL-5 Designated Lubricants
 Approximate Unit Weight: 80 lb.

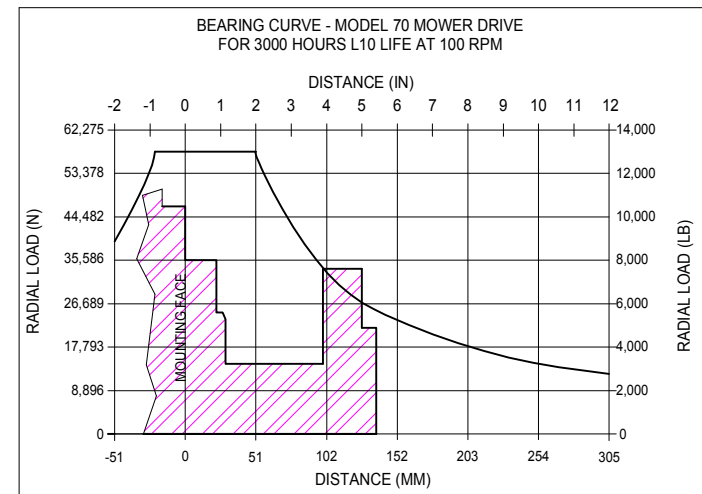

To adjust for loads and speeds other than those shown on above curve, use this formula:

$$\text{Adjusted Life (hours)} = 3000 \left(\frac{100 \text{ rpm}}{\text{Speed (Adjusted)}} \right) \times \left(\frac{\text{Load (Curve)}}{\text{Load (Adjusted)}} \right)^{10/3}$$



BEARING ADAPTERS

Direct Drive Bearing Housings
Typical Applications: Brush Cutting

(913) 782-1238 (Tel)
(913) 782-4206 (Fax)
Sales@Eskridgeinc.com
www.Eskridgeinc.com
FORM: PSMD-B
SHEET 6 OF 10

MODEL 70

Ordering Information

Example Part Number: 70LM1S4C4-1

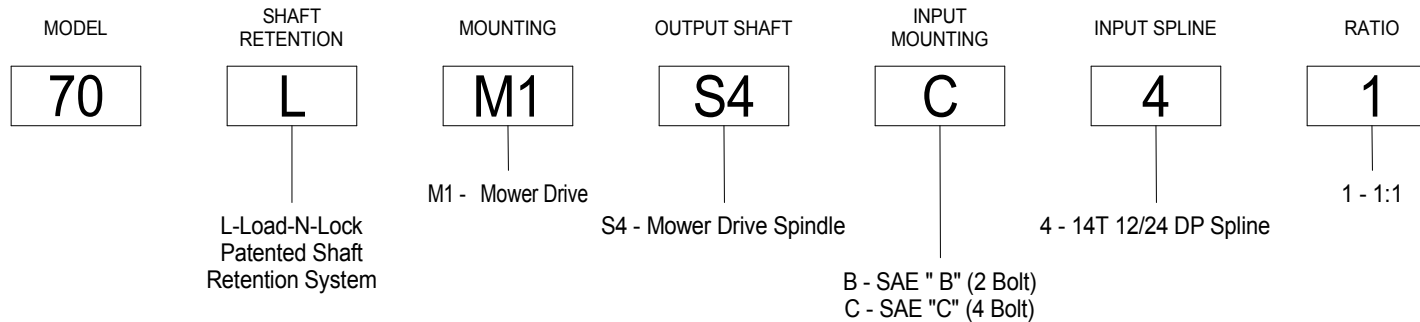



BEARING ADAPTERS

Direct Drive Bearing Housings
Typical Applications: Brush Cutting

(913) 782-1238 (Tel)
(913) 782-4206 (Fax)
Sales@Eskridgeinc.com
www.Eskridgeinc.com
FORM: PSMD-B
SHEET 7 OF 10

MODEL 132

MOTOR MOUNT
SAE 'C' 2 & 4-BOLT

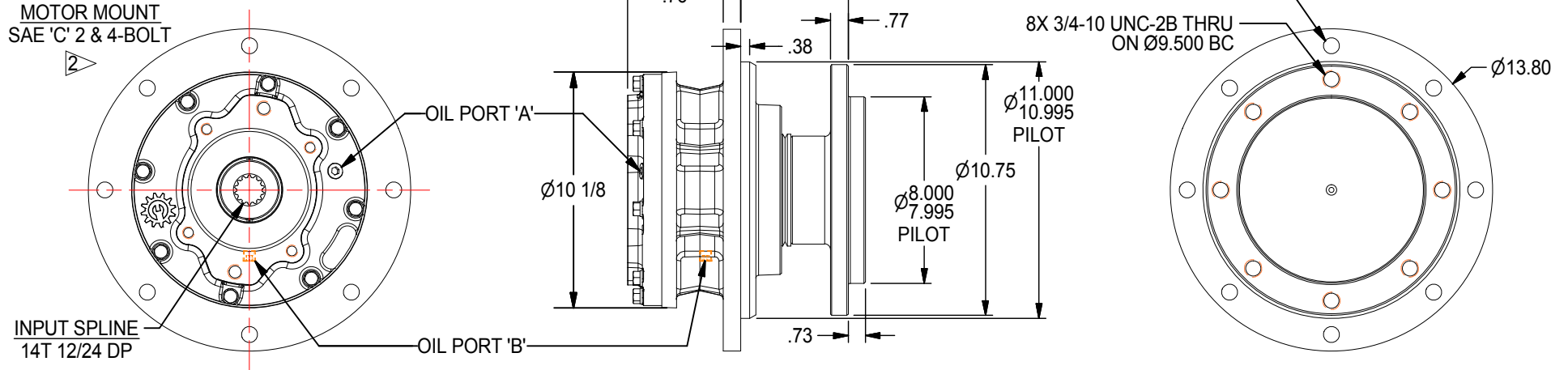

NOTES:

1. EQUIPPED WITH PATENTED LOAD-N-LOCK[®] SHAFT RETENTION SYSTEM.
2. SPECIFICATIONS DEFINED IN MOTOR MOUNT DIMENSIONS SECTION
3. VALUES ARE SHOWN IN INCHES.
4. OUTPUT ROTATION SAME DIRECTION AND SPEED AS INPUT ROTATION.

Oil Capacities

Mounting Position	
Vertical Spindle Down	17 oz/.50 L. Fill to Oil Port 'A' while held in horizontal position as shown

ALL UNITS SHIPPED WITHOUT OIL
Use EP or API GL-5 Designated Lubricants
Approximate Unit Weight: 135 lb.

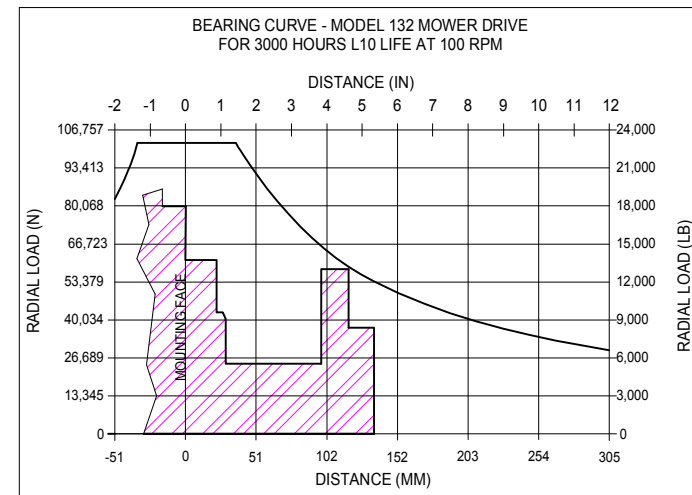

To adjust for loads and speeds other than those shown on above curve, use this formula:

$$\text{Adjusted Life (hours)} = 3000 \left(\frac{100 \text{ rpm}}{\text{Speed (Adjusted)}} \right) \times \left(\frac{\text{Load (Curve)}}{\text{Load (Adjusted)}} \right)^{10/3}$$



BEARING ADAPTERS

Direct Drive Bearing Housings
Typical Applications: Brush Cutting

(913) 782-1238 (Tel)
(913) 782-4206 (Fax)
Sales@Eskridgeinc.com
www.Eskridgeinc.com
FORM: PSMD-B
SHEET 8 OF 10

MODEL 132

Ordering Information

Example Part Number: 132LM1S4C4-1

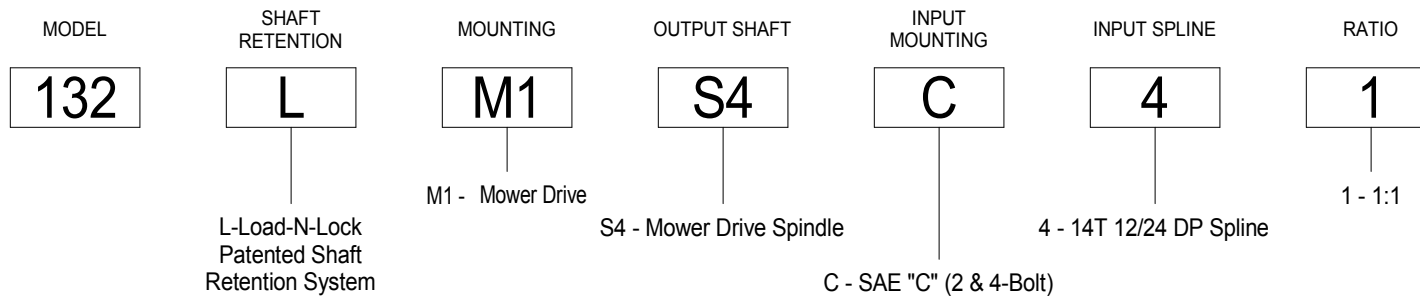

MODEL 252

MOTOR MOUNT
SAE 'D' 4-BOLT

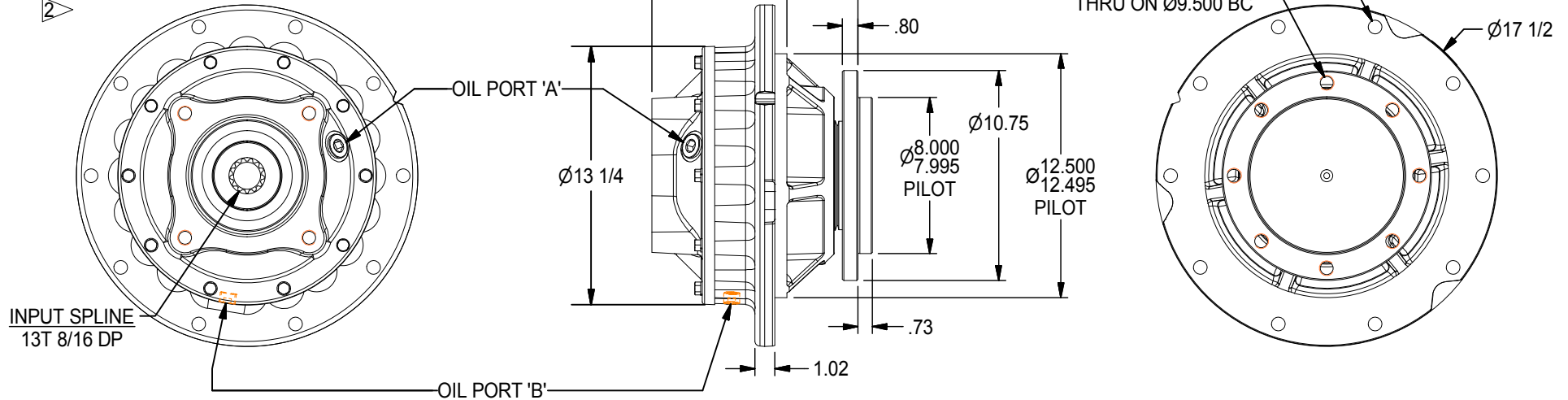

NOTES:

1. EQUIPPED WITH PATENTED LOAD-N-LOCK SHAFT RETENTION SYSTEM.
2. SPECIFICATIONS DEFINED IN MOTOR MOUNT DIMENSIONS SECTION
3. VALUES ARE SHOWN IN INCHES.
4. OUTPUT ROTATION SAME DIRECTION AND SPEED AS INPUT ROTATION.

Oil Capacities

Mounting Position	
Vertical Spindle Down	4.0 PINTS (1.89L) FILL TO: BOTTOM OF PORT 'A'
Horizontal	4.0 PINTS (1.89L) FILL TO: BOTTOM OF PORT 'A'

ALL UNITS SHIPPED WITHOUT OIL.
Use EP or API GL-5 Designated Lubricants
Approximate Unit Weight: 135 lb.

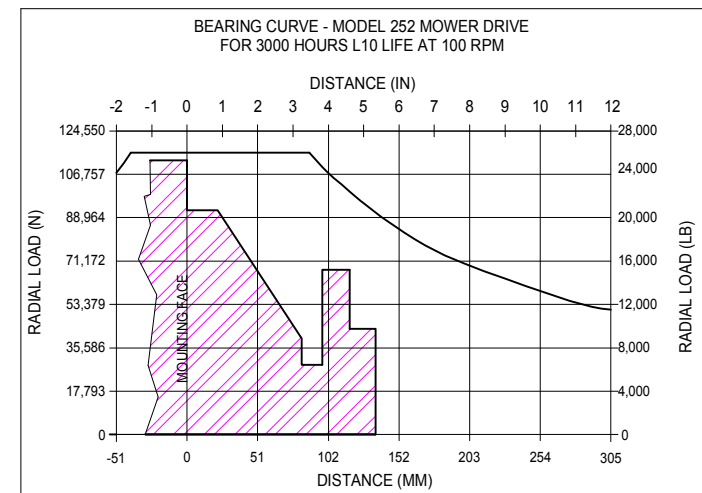

To adjust for loads and speeds other than those shown on above curve, use this formula:

$$\text{Adjusted Life (hours)} = 3000 \left(\frac{100 \text{ rpm}}{\text{Speed (Adjusted)}} \right) \times \left(\frac{\text{Load (Curve)}}{\text{Load (Adjusted)}} \right)^{10/3}$$



BEARING ADAPTERS

Direct Drive Bearing Housings
Typical Applications: Brush Cutting

(913) 782-1238 (Tel)
(913) 782-4206 (Fax)
Sales@Eskridgeinc.com
www.Eskridgeinc.com
FORM: PSMD-B
SHEET 10 OF 10

MODEL 252

Ordering Information

Example Part Number: 252LM1S4D9-1

